

B28x4

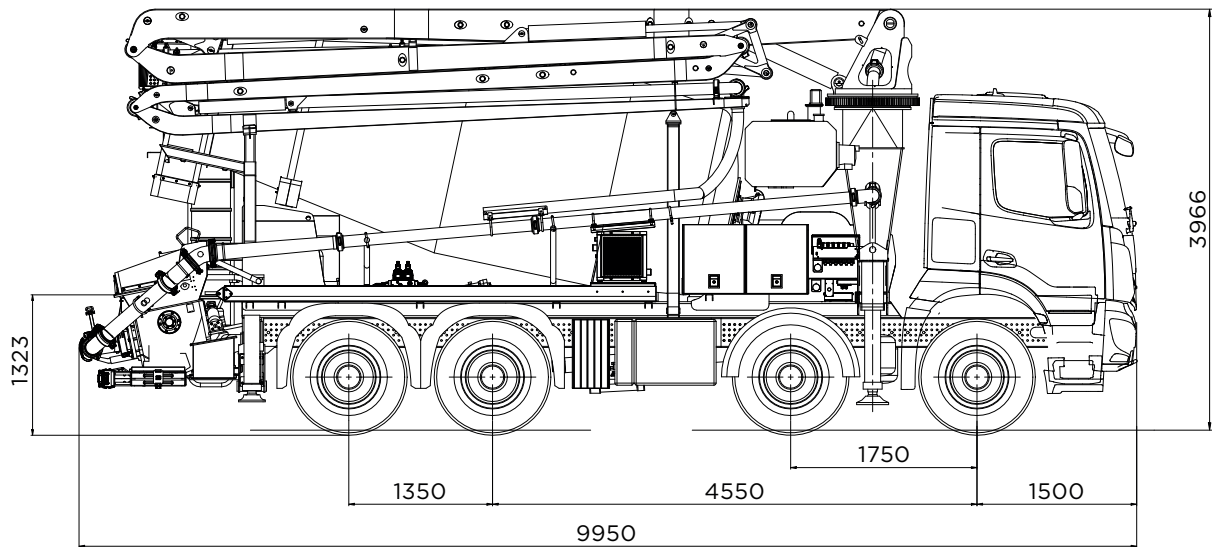

dimensions are informative and depend on the truck composition chosen

PUMPING UNIT XJG5320

max. concrete flow rate*	60 m ³ /h
max. concrete pressure*	75 bar
max. number of strokes	31/min
stroke length	1000 mm
diameter of concrete cylinder	200 mm
hopper capacity	500 l

*the data given are theoretical values and cannot be reached simultaneously.

MIXER DRUM 7,5 m³

nominal capacity	7,5 m ³
geometric volume	12,0 m ³
rotation speed	0 - 15/min
water counter	0 - 500 l
material	QSTE 500*

- powered by PTO transmission of the truck
- s-valve made of wear-resistant cast iron, equipped with a welded wear layer
- wear ring and wear plate with compensation system with inlay of tungsten carbide steel
- electric driven and temperature controlled oil cooler
- mixing shaft with removable blades, fitted with a welded wear layer
- automatic grease lubrication system, hydraulically driven
- thick-walled 5" outlet bend with flushing hole
- concrete cylinder with hard chrome inner wall
- simply designed open hydraulic system
- electro-hydraulic controlled pumping unit
- separate control for pumping and s-valve cylinders supported with accumulator
- fuel-saving flow and speed control
- Rexroth hydraulic pumps with variable displacement
- sensor in the concrete drum for automatic discharge of the concrete mixer
- constant speed of the mixer drum, independent of the truck engine speed



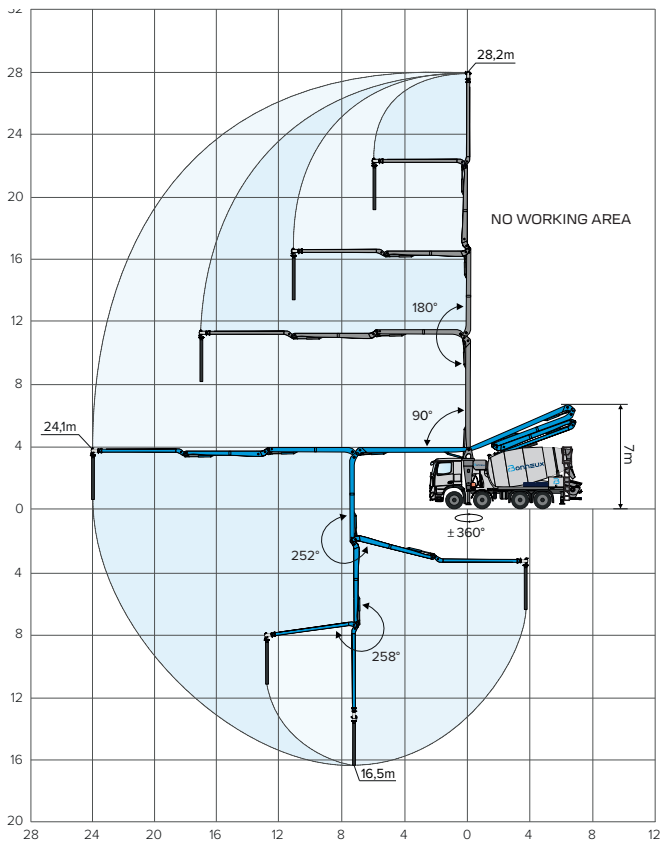

BOOM B28x4	
material	high-strength structural steel
strength calculation	FEM analyse
folding system	type 'z'
number of sections	4
max. vertical range	28,2 m
max. horizontal range	24,1 m
max. depth range	16,5 m
min. unfolding height	7,0 m
rotation angle	± 360°
turning angles	90°- 180°- 252°- 258°
control valve	proportional
max. hydraulic pressure	350 bar
pipeline	Ø 4" (DN 100)
end hose	Ø 4" (DN 100) - 3 m

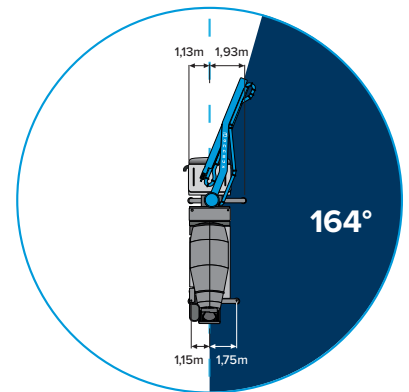
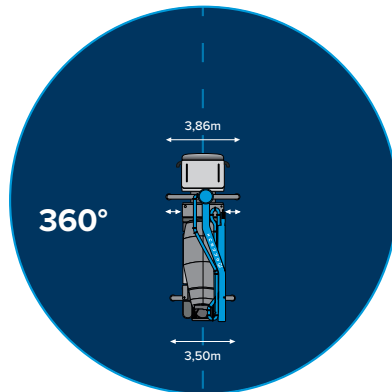
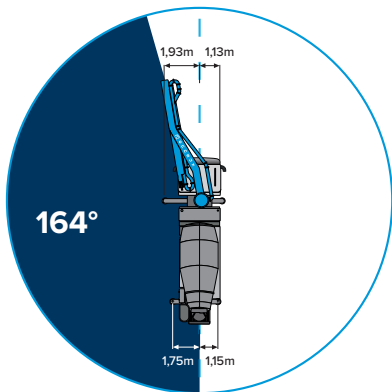

RADIO REMOTE CONTROL
2 TRANSMITTERS + 1 RECEIVER



HYDRAULIC CONTROL BOOM
PROPORTIONAL DIRECTIONAL
SPOOL VALVE

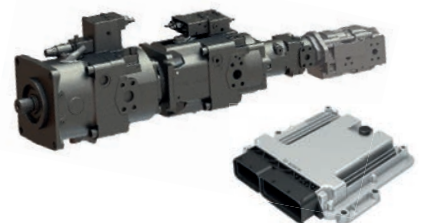

HYDRAULIC PUMPS
ELECTRONIC CONTROL UNIT
BODAS HARDWARE
CONTROLLER RC SERIES

our products are constantly evolving, which means specifications may vary